

RHODO

rhodobyozdesign.weebly.com

2020 - June

C
O
N
T

1. Abstract & Introduction
2. Brand Extension
3. Research
5. Market Positioning
6. Sector Charts
7. Target Group
8. Final Brief
9. Moodboard & Shape Inspirations
10. Sketches
12. Process

E

N

T

S

15.

Logo Design

16.

RHODO

18.

Technical Features

21.

How to Combine

22.

Conceptual Showroom

23.

Promotional Items

30.

Packaging

32.

User Manual

33.

Designer

35.

Thanks to

ABSTRACT

Özge İLHAN,

started designing minimal furniture in 2017 as ÖZ DESIGN. The aim of the company is to design minimal, functional, portable and elegant furniture for mainly tiny places.

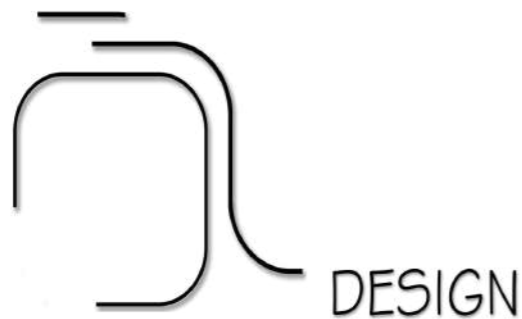

Rhodo,

is a brand extension of ÖZ DESIGN, which increases efficiency by adding extra functions and combinations, beside their basic concepts, that have become part of daily life.

INTRODUCTION

BRAND EXTENSION

RHODO Series designed by Özge İLHAN as a brand extension of ÖZ Design. Inspired from flamingos to create an aesthetic and elegant minimalism in design for young adults and flexible spaces.



LAPTOP DIMENSIONS

- 11 inch (For 11-11.6 inch Laptop): 310*220*25mm
- 13 inch (For 13-13.3 inch Laptop): 340*240*25mm
- 14 inch (For 14-14.5 inch Laptop): 360*260*25mm
- 15 inch (For 15-15.6 inch Laptop): 385*290*2.5mm
- 17 inch (For 16-17.4 inch Laptop): 440*320*2.5mm

dimensions

functions

regulations

inspirations

REGULATIONS

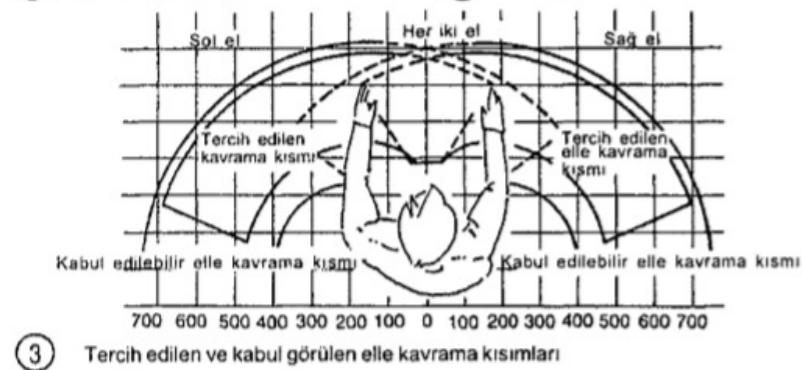
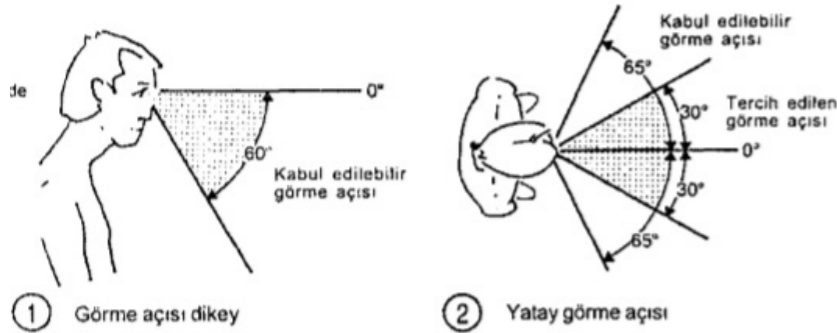

HUMAN SCALE

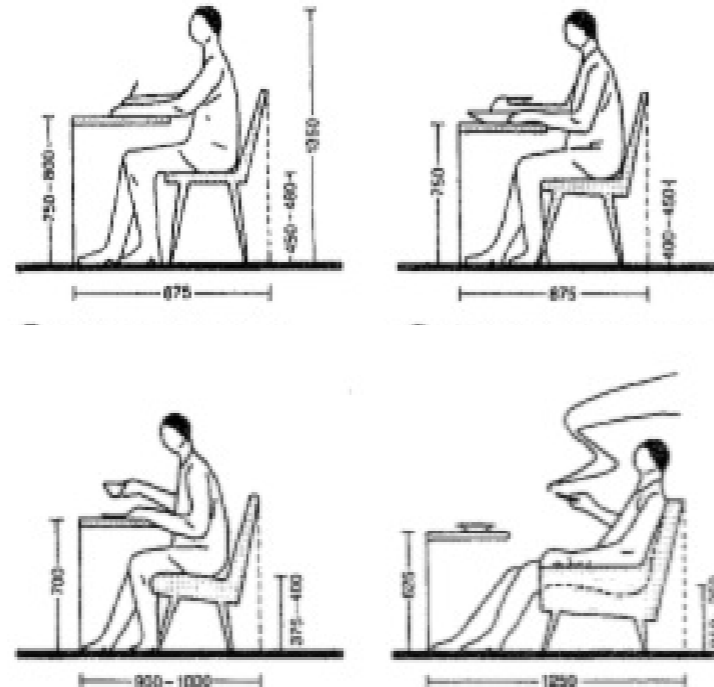

RESEARCH

*** Ernst Neufert - Architect's Data



FLAMINGO

- Functional anatomy
- Color variation of furs
- Both angular and curvature form
- Elegant and slender sizes

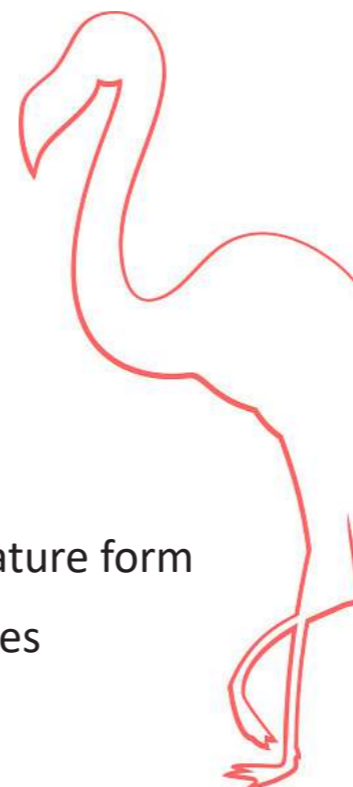

- Needs of the client
- Limits of the materials
- Requirements of the object
- Opportunities of the space
- Conceptual design understanding

MARKET POSITIONING

basic usage

complex design

quality

brand fame

affordability

luxury

functionality

standart usage



QUALIFIED

MIDDLE RANGED

MINIMAL

SECTOR CHARTS

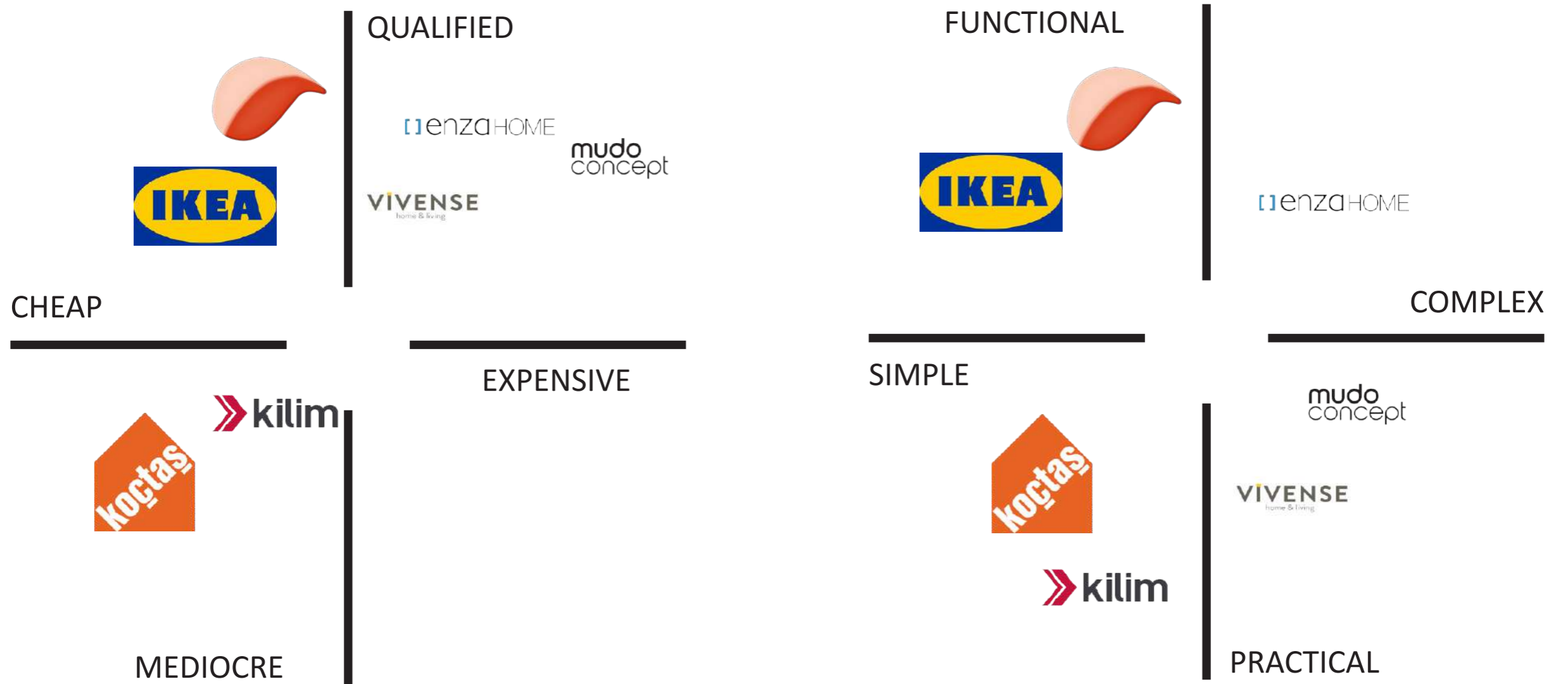

TARGET GROUP



young - adults (20 - 35)

minimalist lifestyle

small space / less furniture

flexible living style

FINAL BRIEF



is designed for middle-ranged young-adults with a minimal lifestyle or tiny house, to ensure maximum efficiency in a functional and minimal understanding by ÖZ DESIGN.



**MOOD
BOARD**



**SHAPE
INSPIRATIONS**

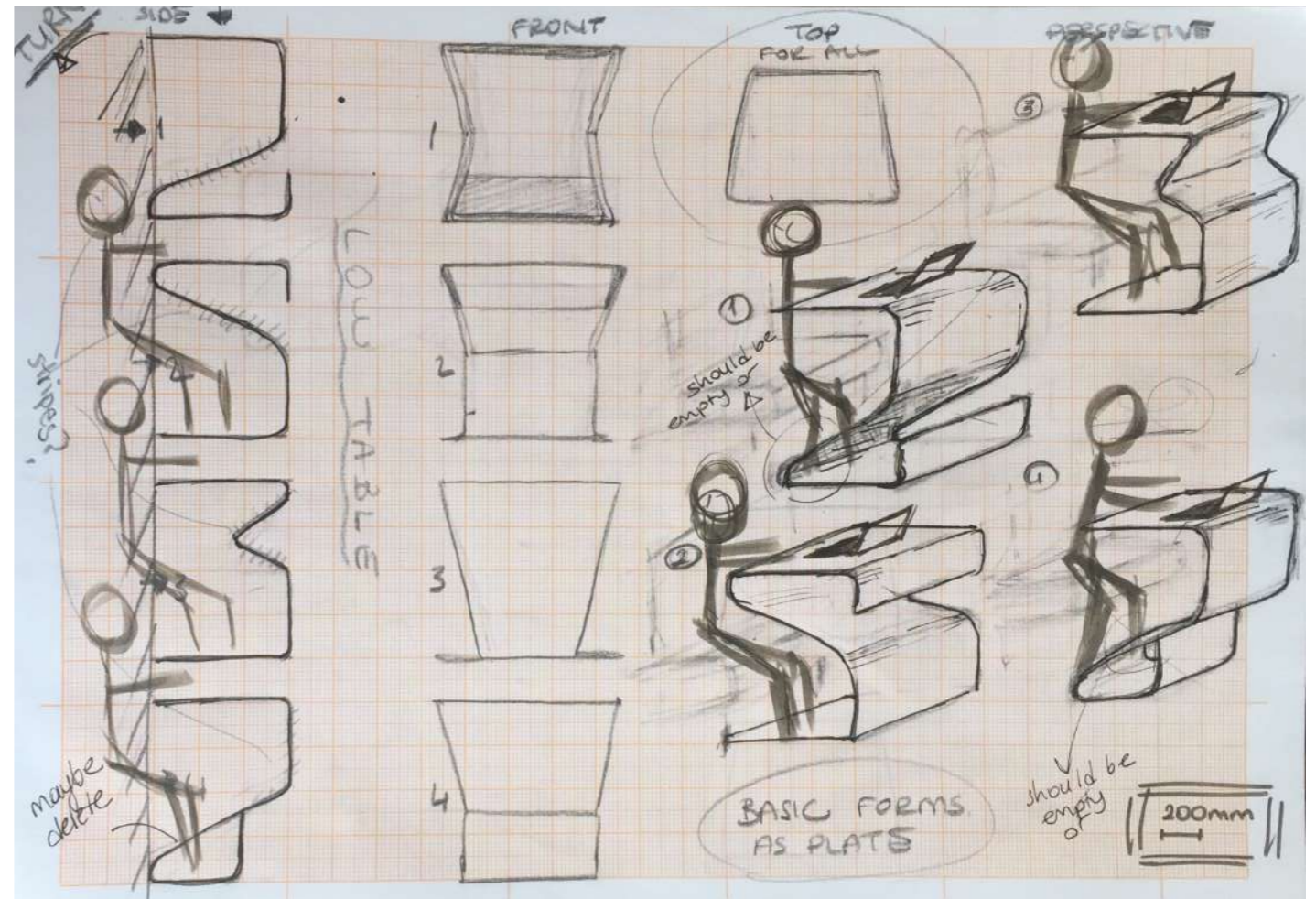
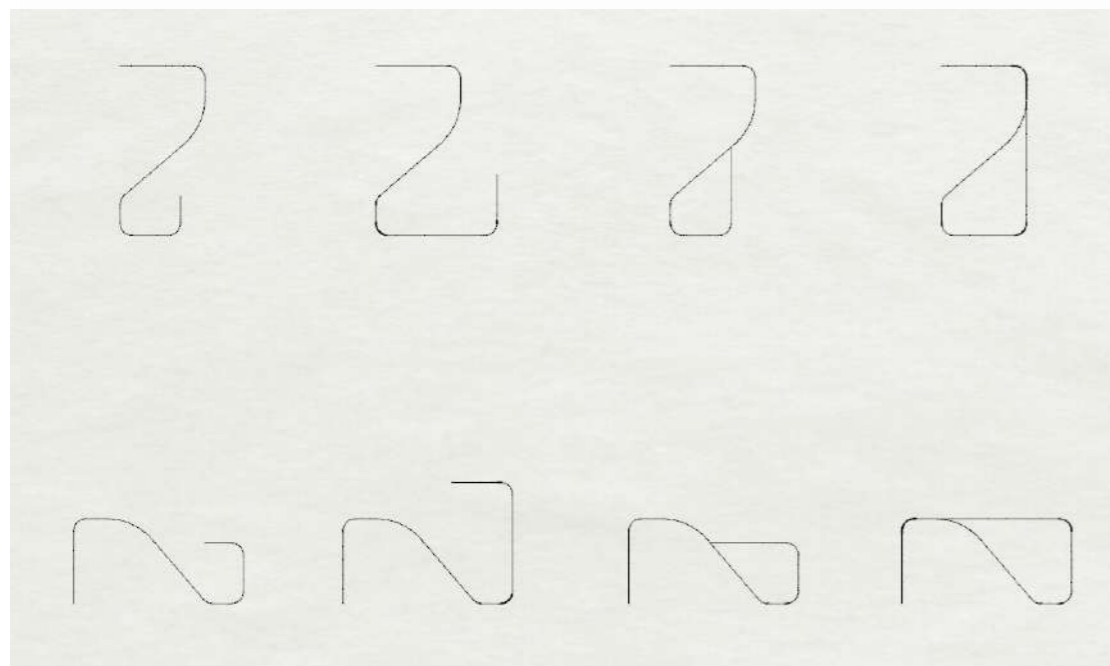
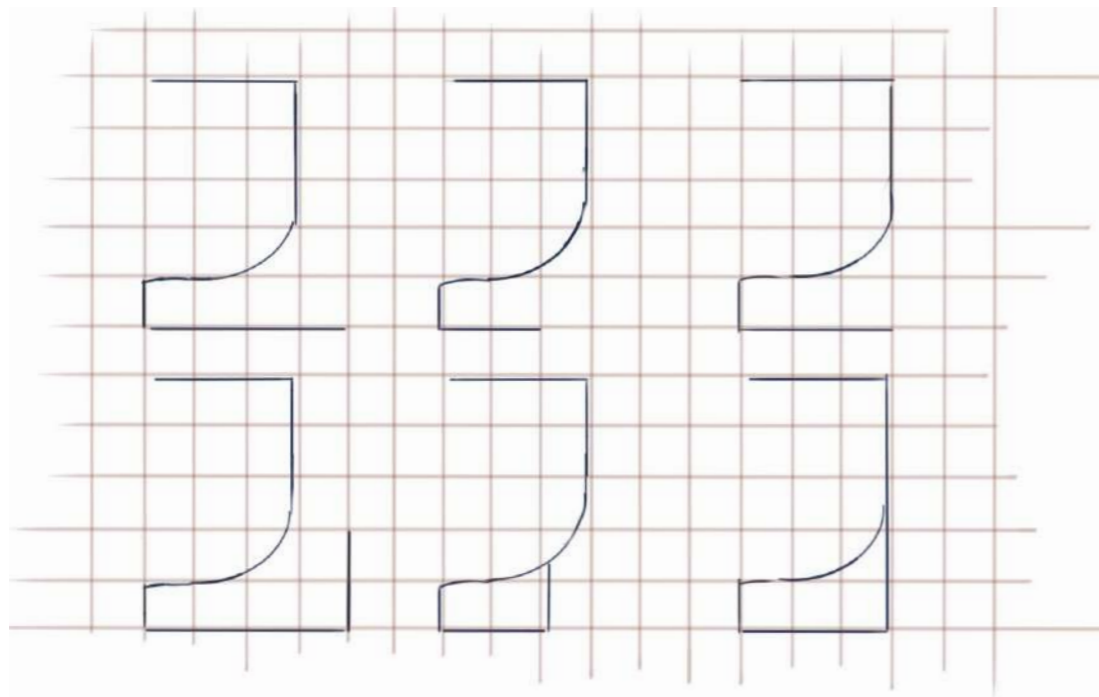

SKETCHES

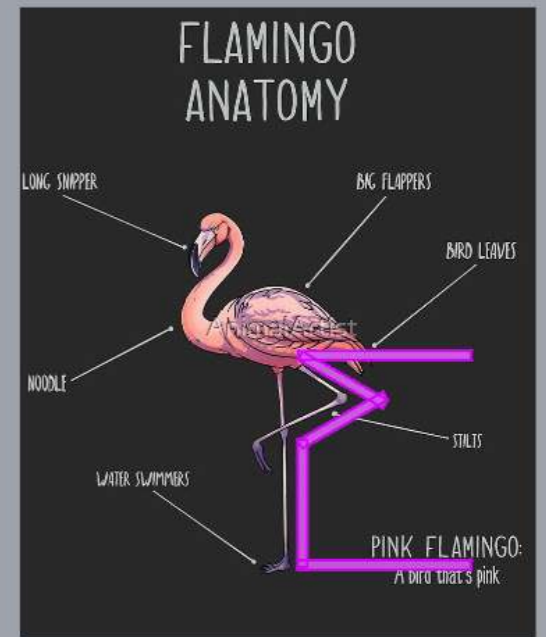
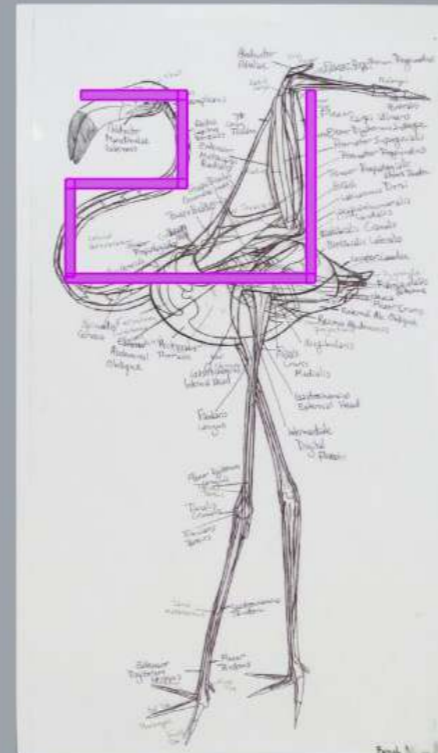
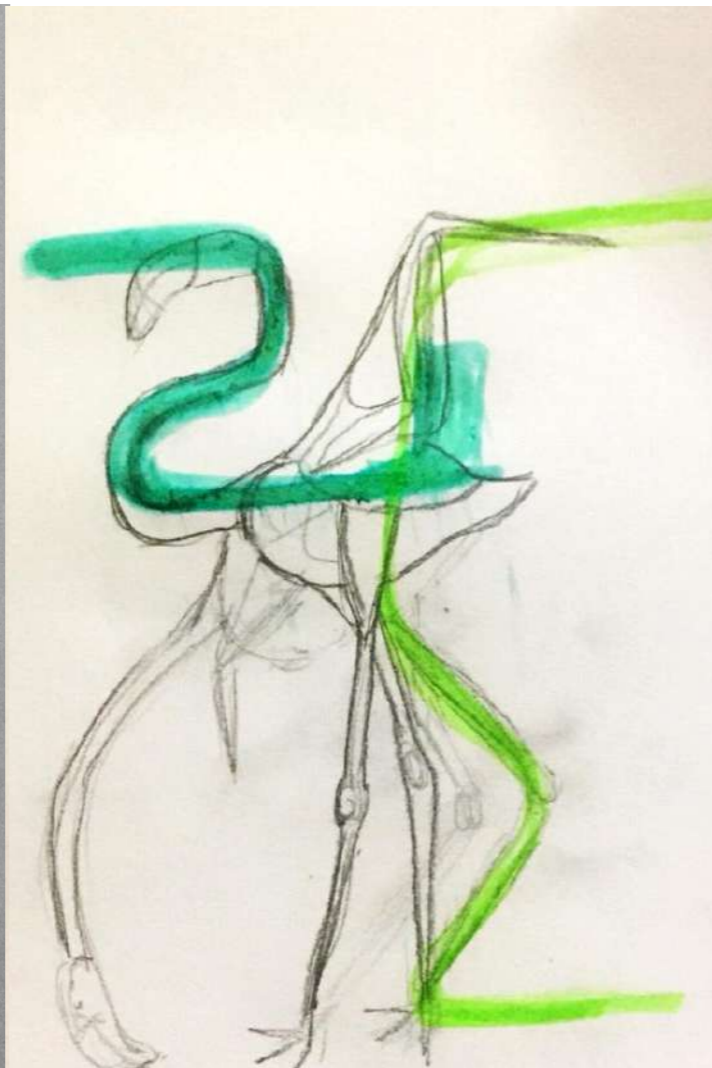

SKETCHES

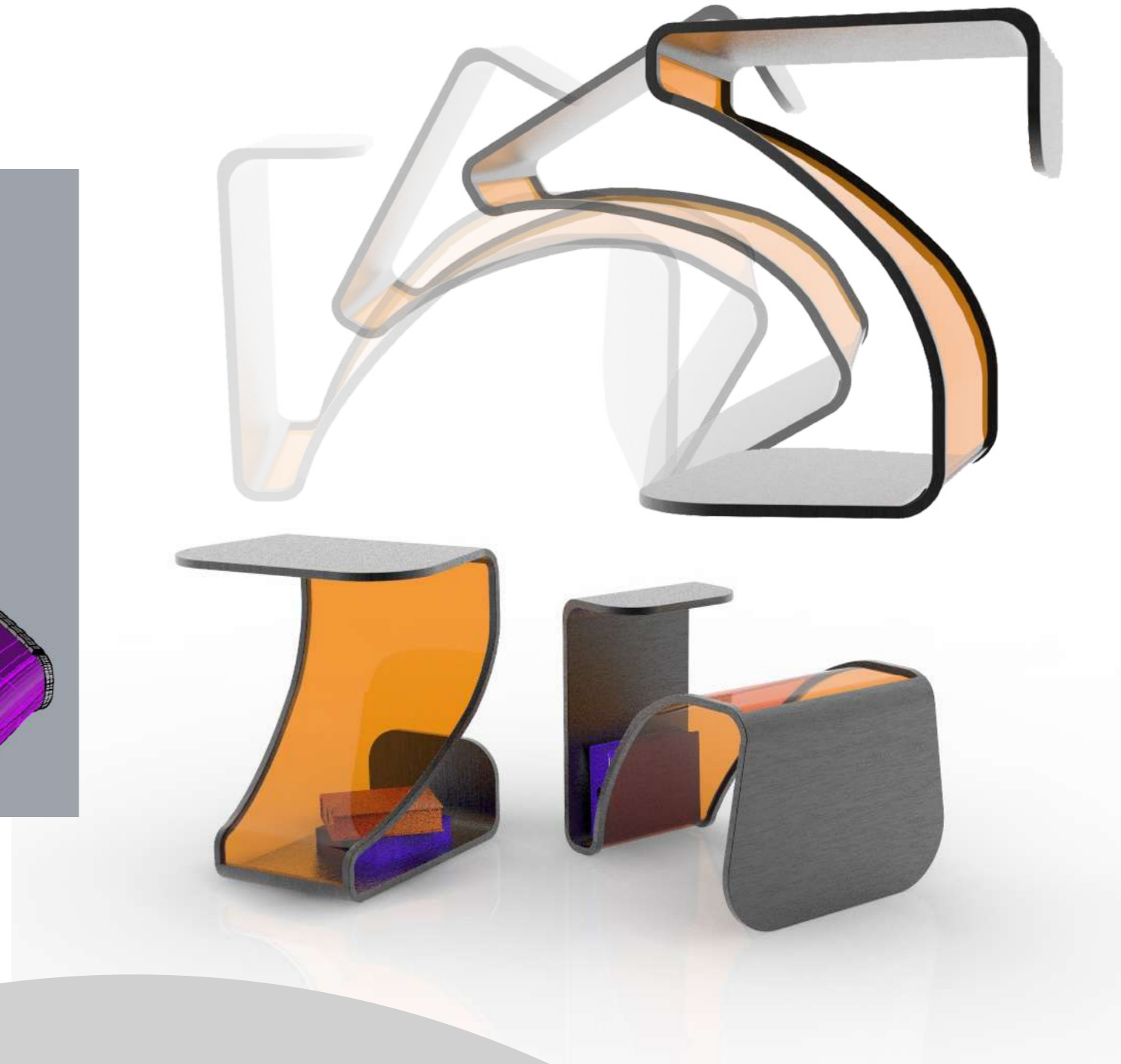
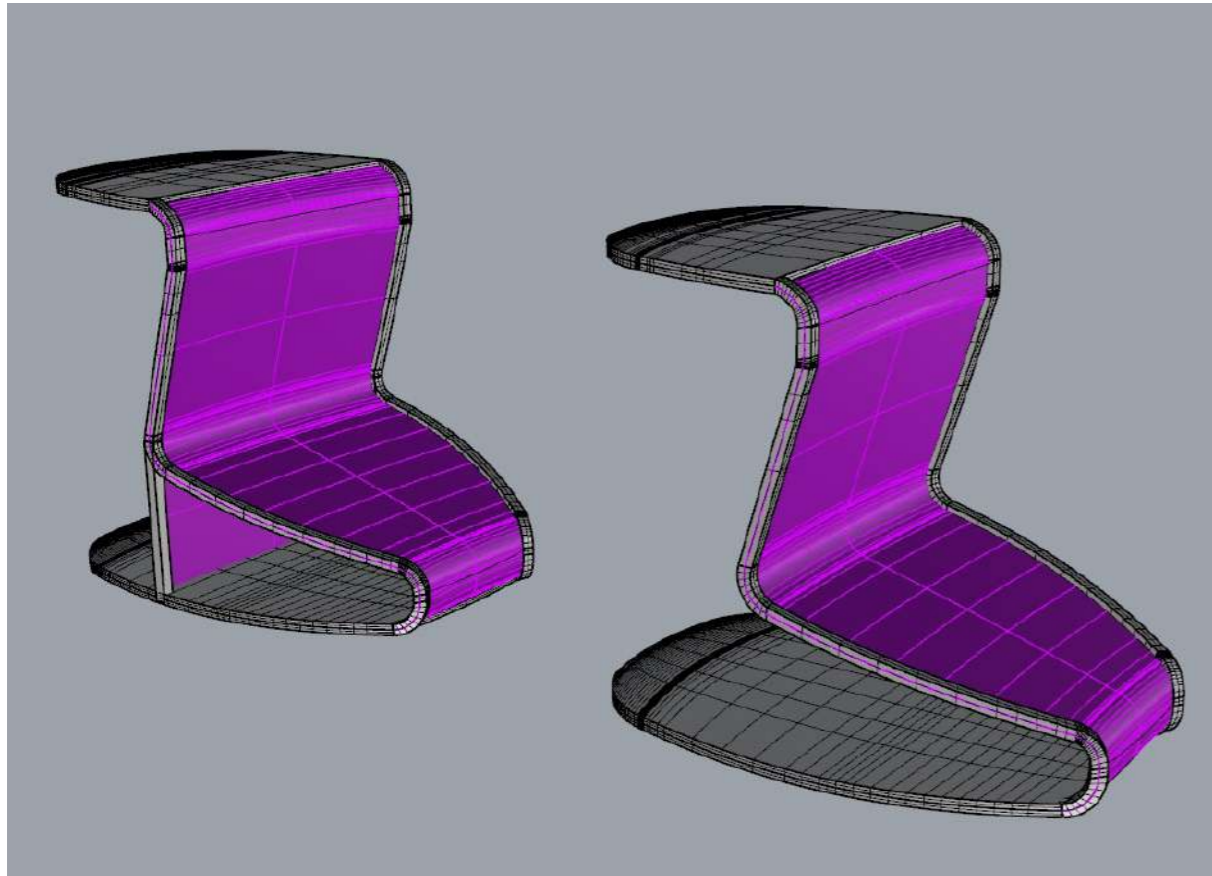

PROCESS



A
L
T
E
R
N
A
T
E
1



A
L
T
E
R
N
A
T
E
3



A
L
T
E
R
N
A
T
E
2



A
L
T
E
R
N
A
T
E
4



PROCESS

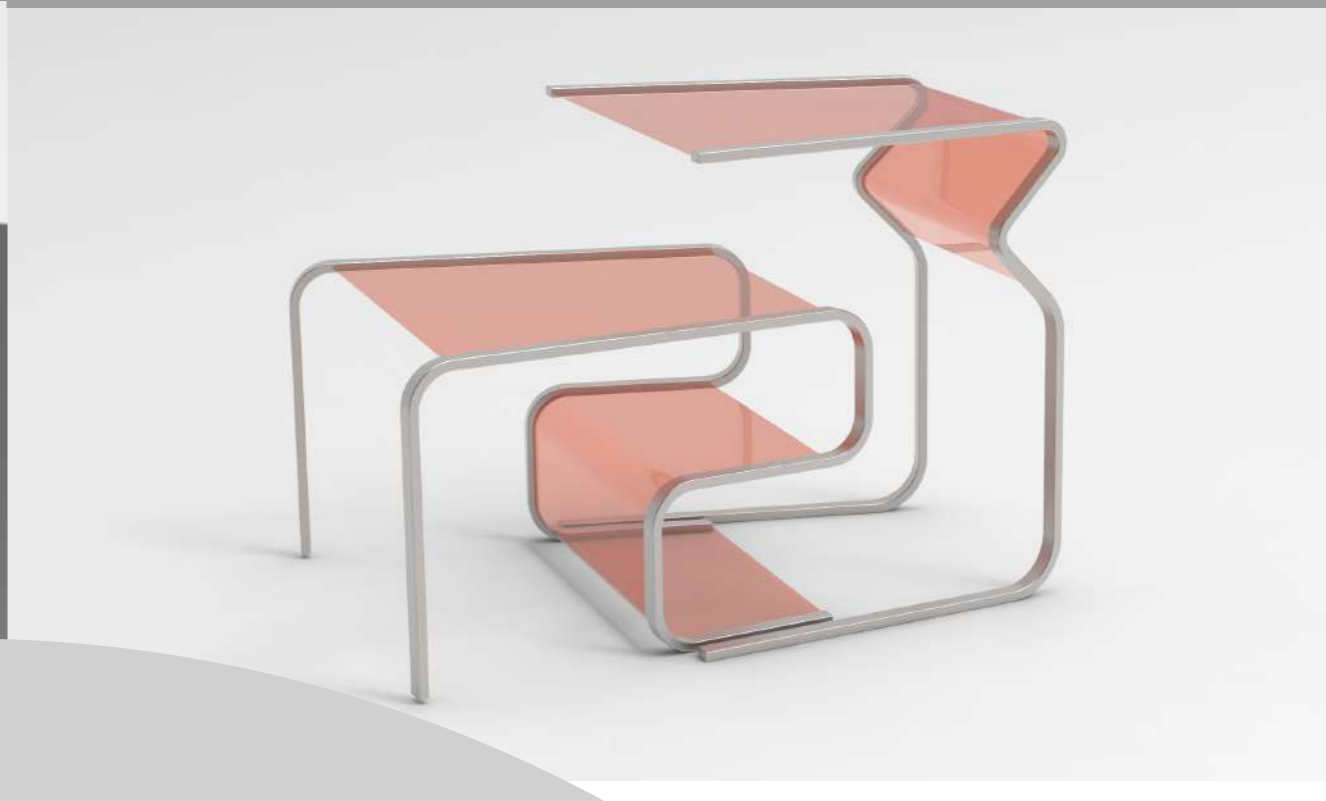
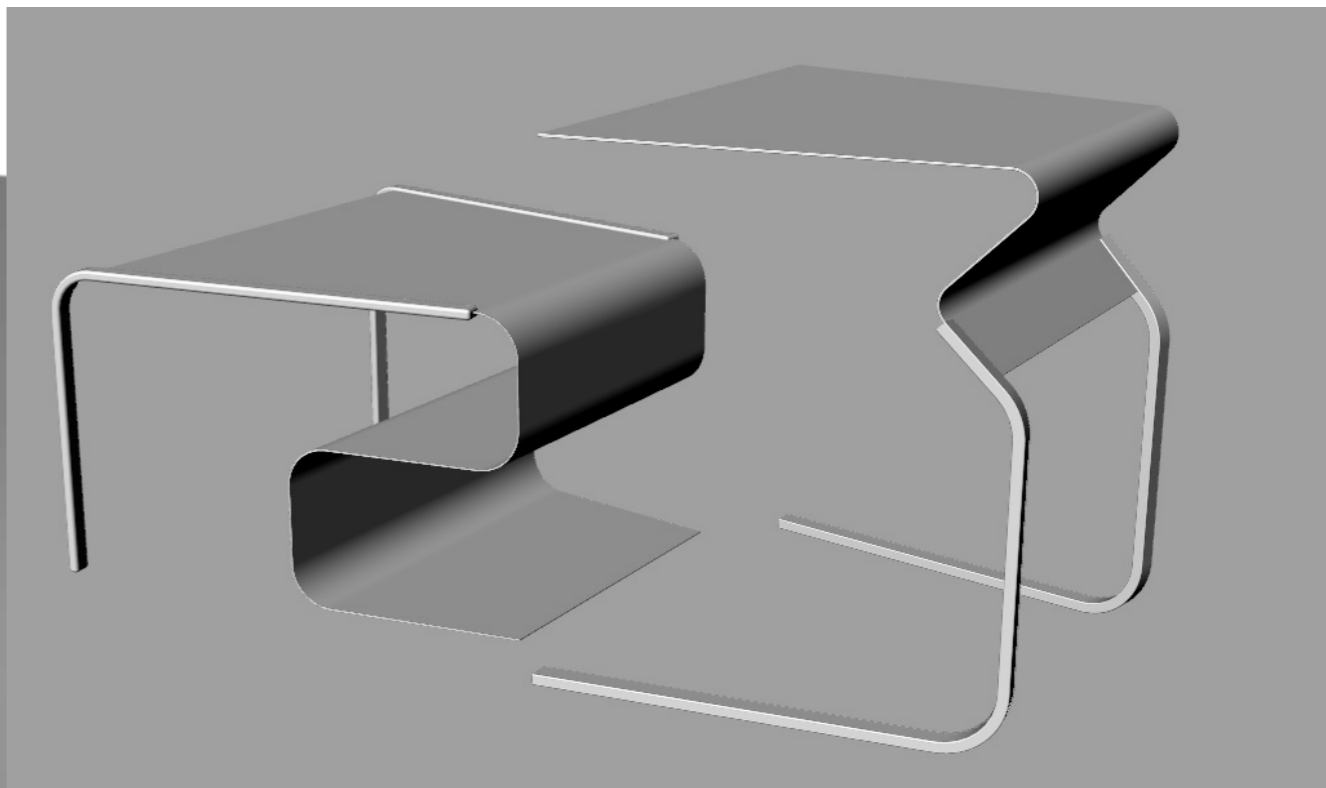

PROCESS

LOGO DESIGN

The logo design is presented on a grid with the following specifications:

- Flamingo Illustration:** A line drawing of a flamingo in profile, facing left. The overall height is 50xx and the width is 40xx. A circular crop mark is centered on the flamingo's head and neck, with a diameter of 16xx.
- Font:** The word "RHODO" is rendered in a bold, black, sans-serif font. The font is identified as "Broadway".
- Color Palette:**
 - SALMON PINK:** CMYK 3.29.28.0, RGB 244.197.179, HEX #F4C5B3
 - REDDISH-ORANGE:** CMYK 9.79.82.1, RGB 217.79.52, HEX #D94F34
- Leaf Motif:** A stylized leaf shape is shown in three variations: a black outline, a solid black fill, and a gradient fill transitioning from salmon pink to reddish-orange. The height of the leaf motif is 6xx.
- Logo Combinations:** Three variations of the logo are shown:
 - The leaf motif above the word "RHODO".
 - The leaf motif to the left of the word "RHODO".
 - The leaf motif to the left of a larger version of the word "RHODO".

RHODO

1 Functional

Provides its function with a simple design.

2 Minimal

Avoids from complexity and massive design.

3 Portable

Light design can be lifted and rotated

Rhodo is designed for efficiency in a minimalist style.

The elegant lines combined with the smooth steel also the warm colors of plexi-glass turned this functional piece into an aesthetical furniture.

Rhodo Series include one high and one low table which can be combined together.

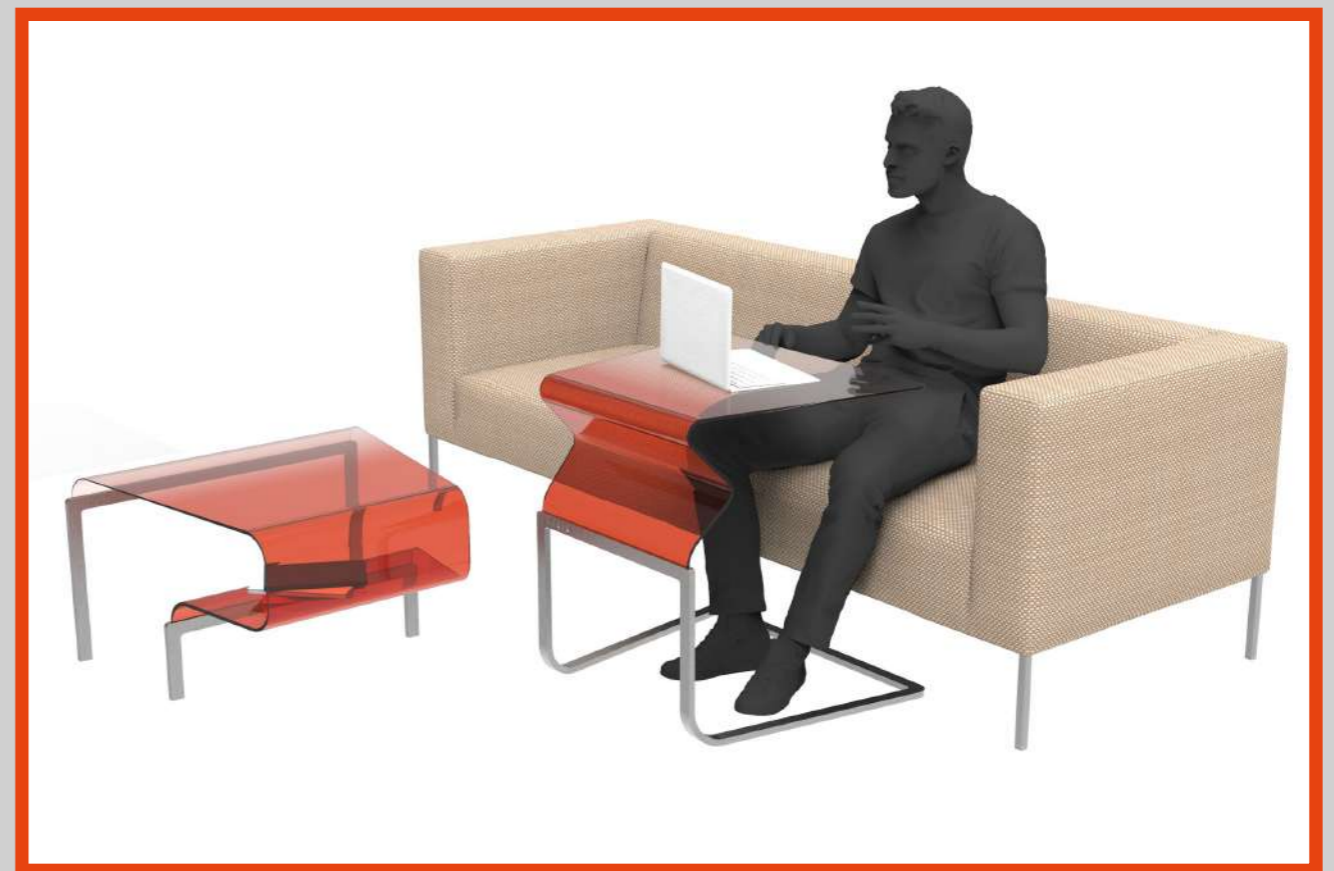

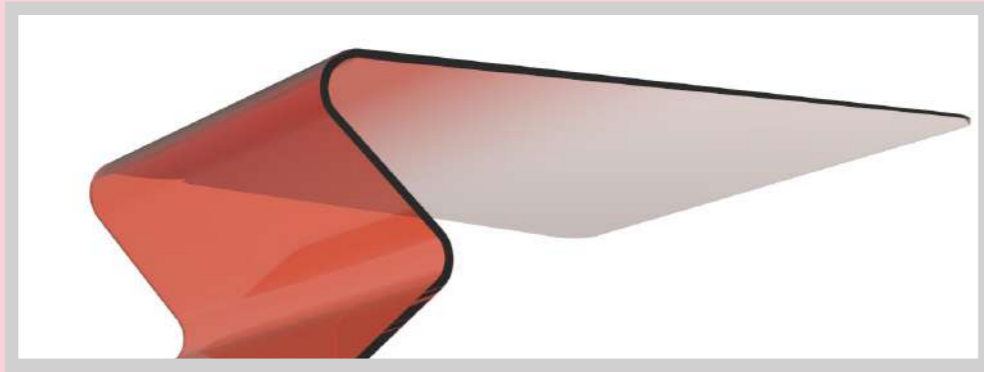

The thickness and color of the plexi-glass changes gradually through the both products forms as a reference to the body shape and fur color of flamingos. Material choice, colors, form and the harmony between two products are also in linked with flamingos.

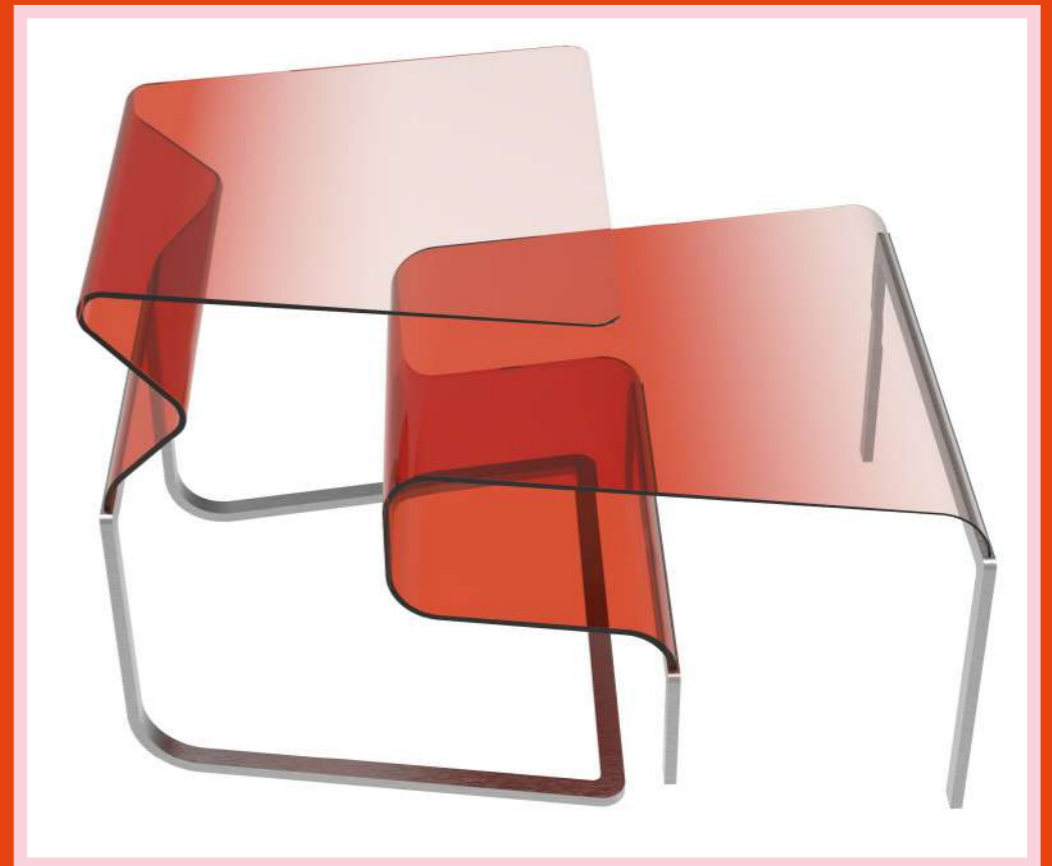



LASER ENGRAVING ON METAL SURFACE
(5mm)

RHODO

150 mm

850 mm

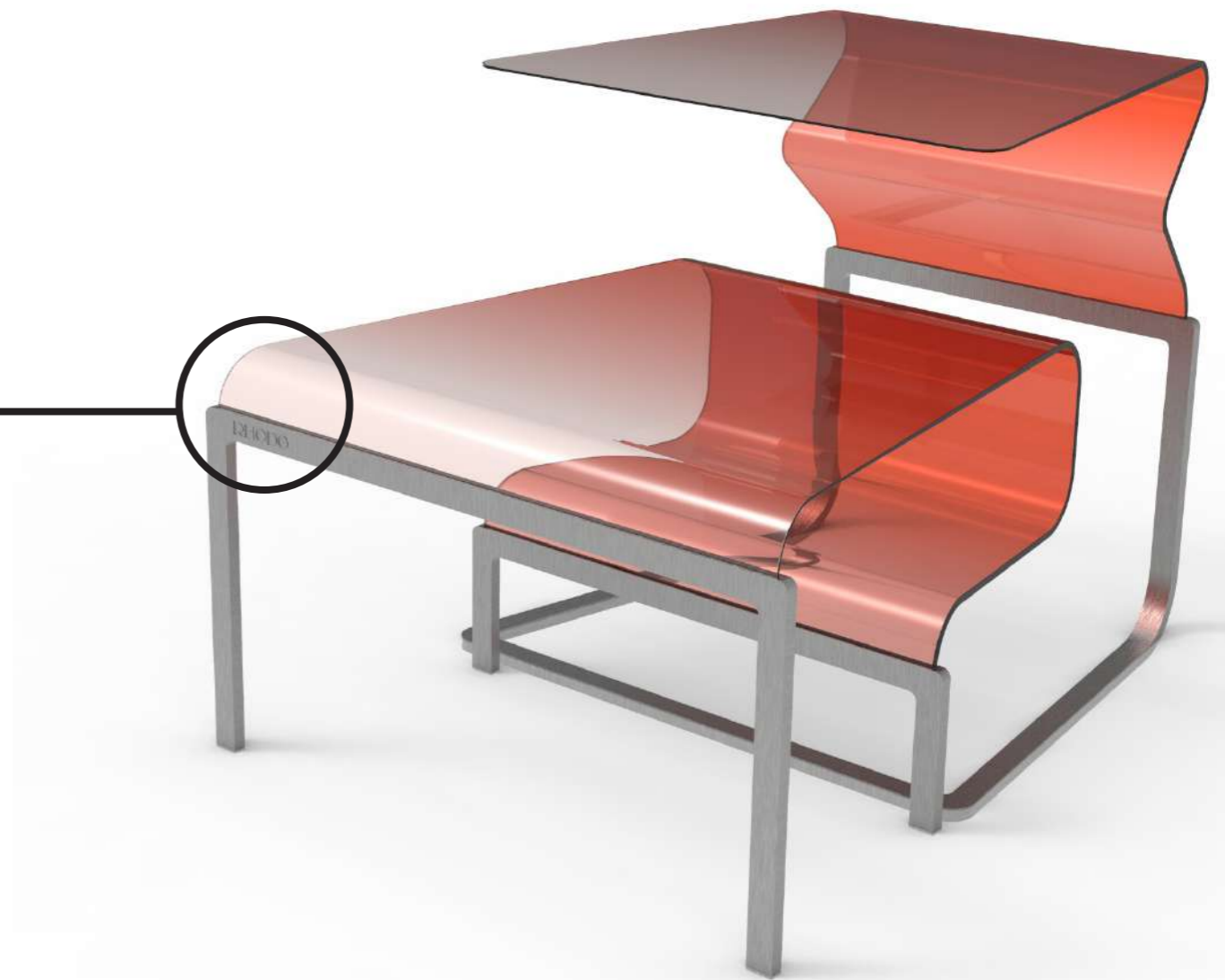

TECHNICAL
FEATURES

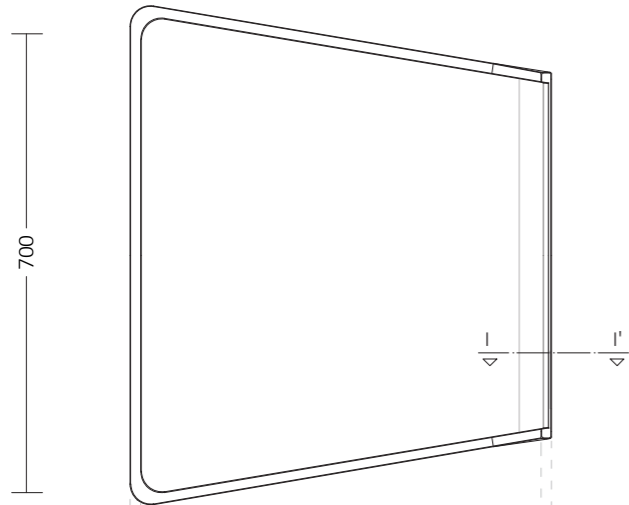

TOP VIEW
SCALE 1:10

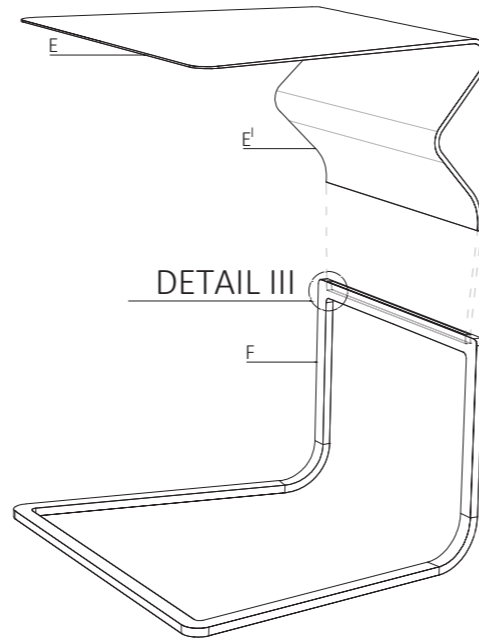

EXPLODED PERSPECTIVE

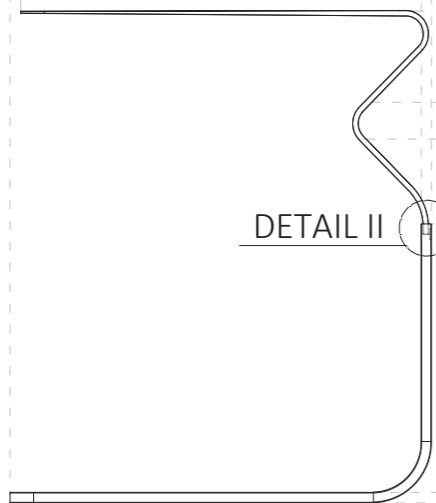
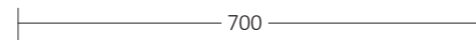

SIDE VIEW
SCALE 1:10

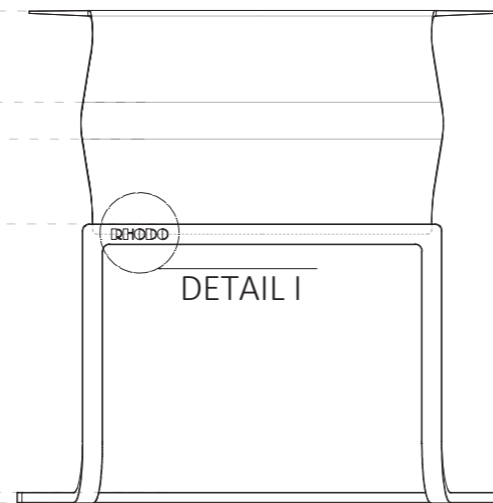

FRONT VIEW
SCALE 1:10

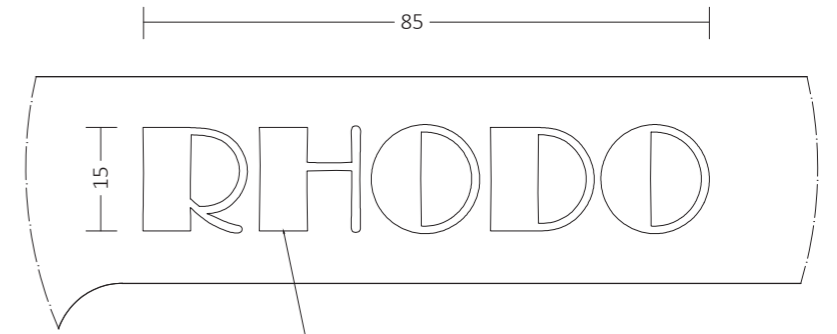

LOGO ENGRAVEMENT
DETAIL I SCALE 1:1
LOGO APPLICATION

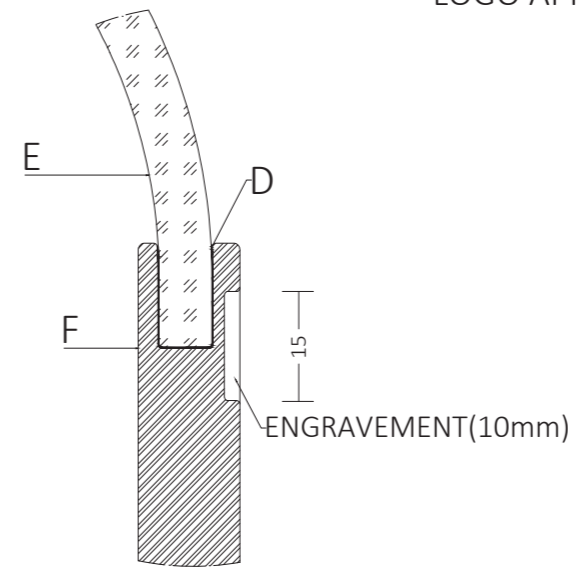

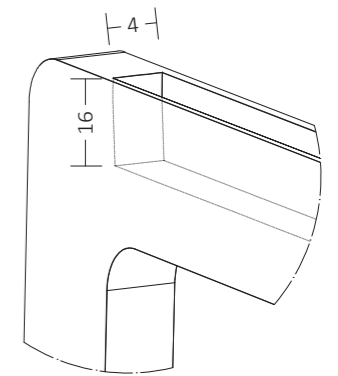

DETAIL II SCALE 1:1
I-I' PARTIAL SECTION



DETAIL III SCALE 1:1
PLEXIGLASS CAVITY

RHODO HIGH TABLE by ÖZ DESIGN - ÖZGE İLHAN

PIECE	MATERIAL	THICKNESS
D	 Polyurethane Sealant	1 mm
E	 Plexiglass	E -> E' = 3->8 mm
F	 Steel Frame	15x30 mm

*All dimensions are given in mm.

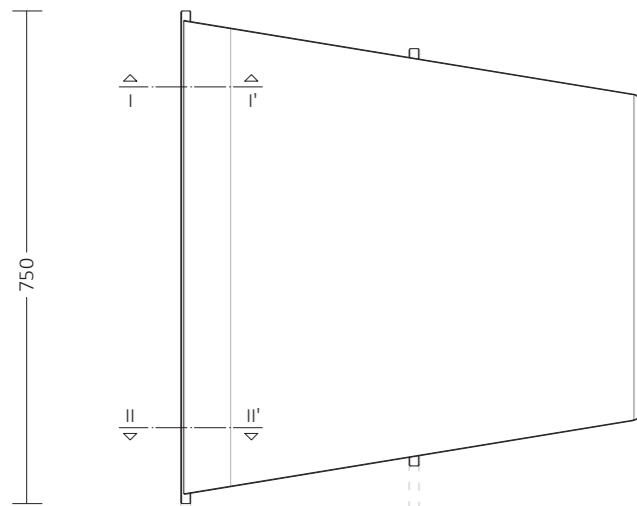

TOP VIEW
SCALE 1:10

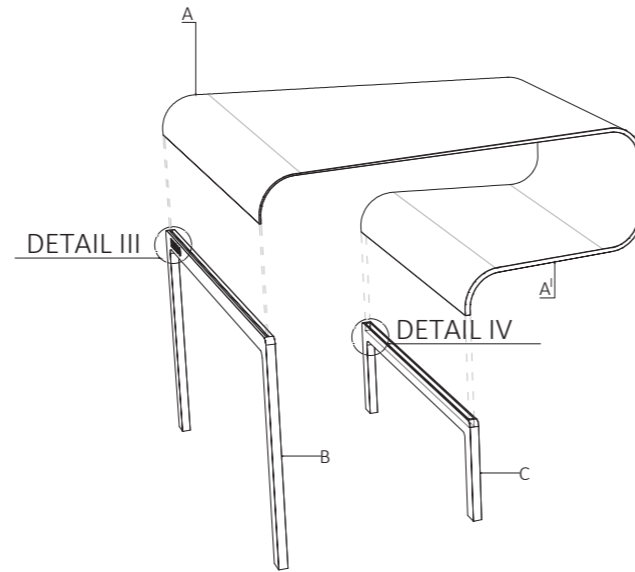

EXPLODED PERSPECTIVE

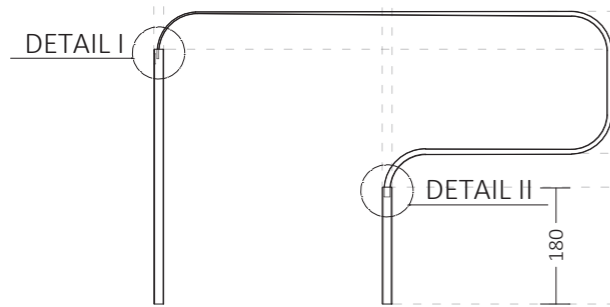
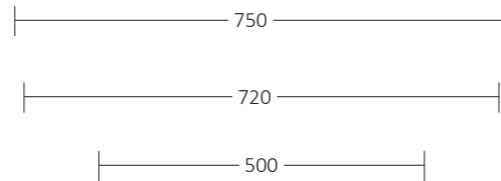

SIDE VIEW
SCALE 1:10

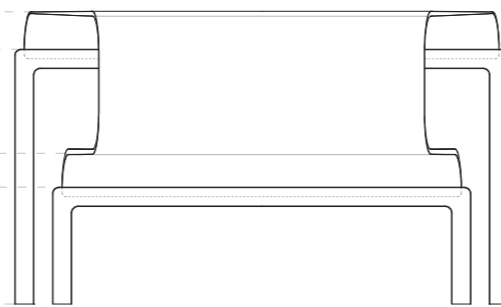

FRONT VIEW
SCALE 1:10

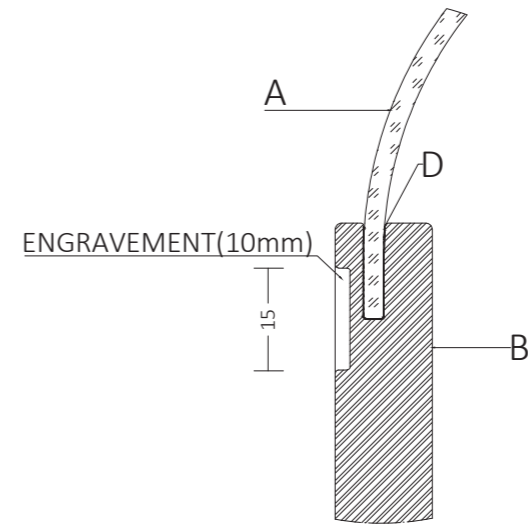

DETAIL I SCALE 1:1
I-I' PARTIAL SECTION

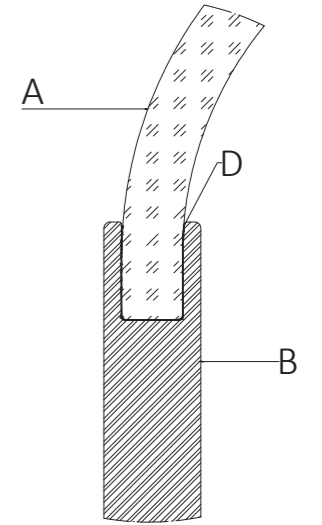

DETAIL II SCALE 1:1
II-II' PARTIAL SECTION

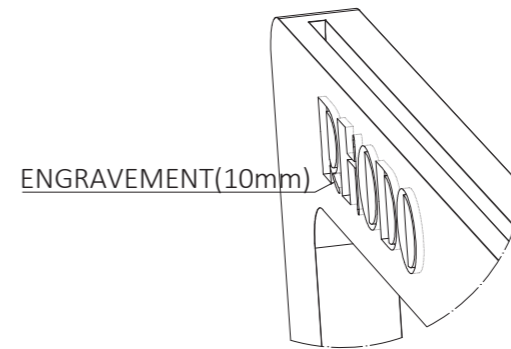

DETAIL III SCALE 1:1
LOGO LASER ENGRAVE

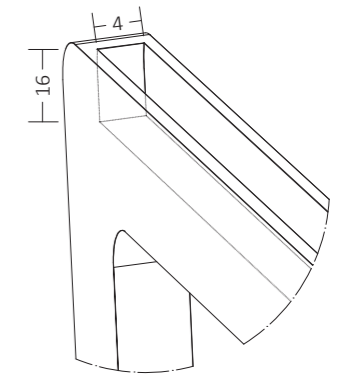

DETAIL IV SCALE 1:1
PLEXIGLASS CAVITY

RHODO LOW TABLE by ÖZ DESIGN - ÖZGE İLHAN

PIECE	MATERIAL	THICKNESS
A	Plexiglass	A -> A' = 3->8 mm
B	Steel Frame	15x30 mm
C	Steel Frame	15x30 mm
D	Polyurethane Sealant	1 mm

*All dimensions are given in mm.

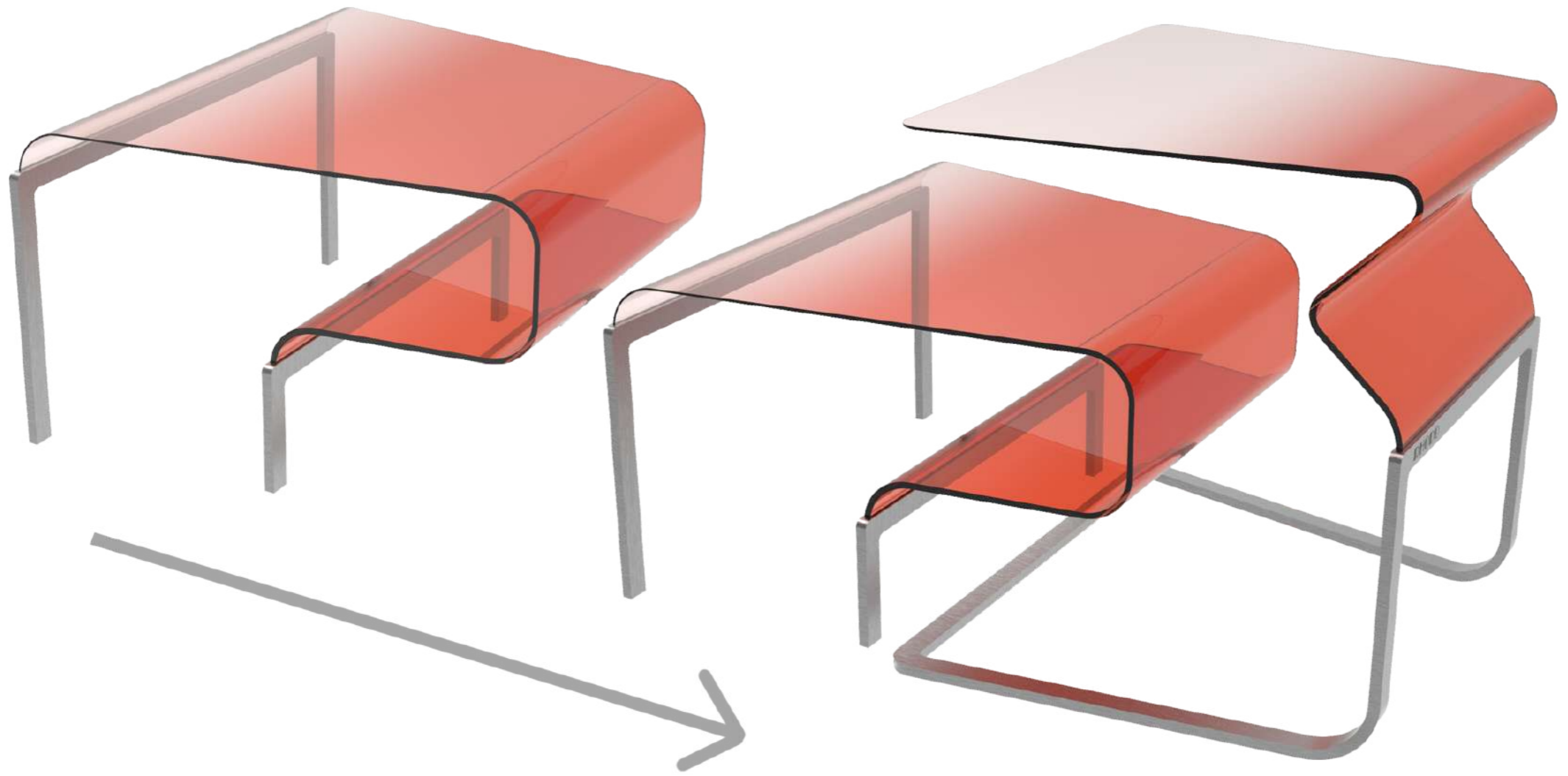

H O W T O C O M B I N E

CONCEPTUAL SHOWROOM



High PC Table **1**



2 Low Coffee Table,

PROMOTIONAL ITEMS

RHODO WALL CLOCK



PROMOTIONAL ITEMS

RHODO CUSHION



1 SIZES

- SMALL (30cm x 30cm)
- MEDIUM (45cm x 45cm)
- LARGE (60cm x 60cm)

2 COVER

- PATTERN
- LOGO

PROMOTIONAL ITEMS

RHODO COASTER

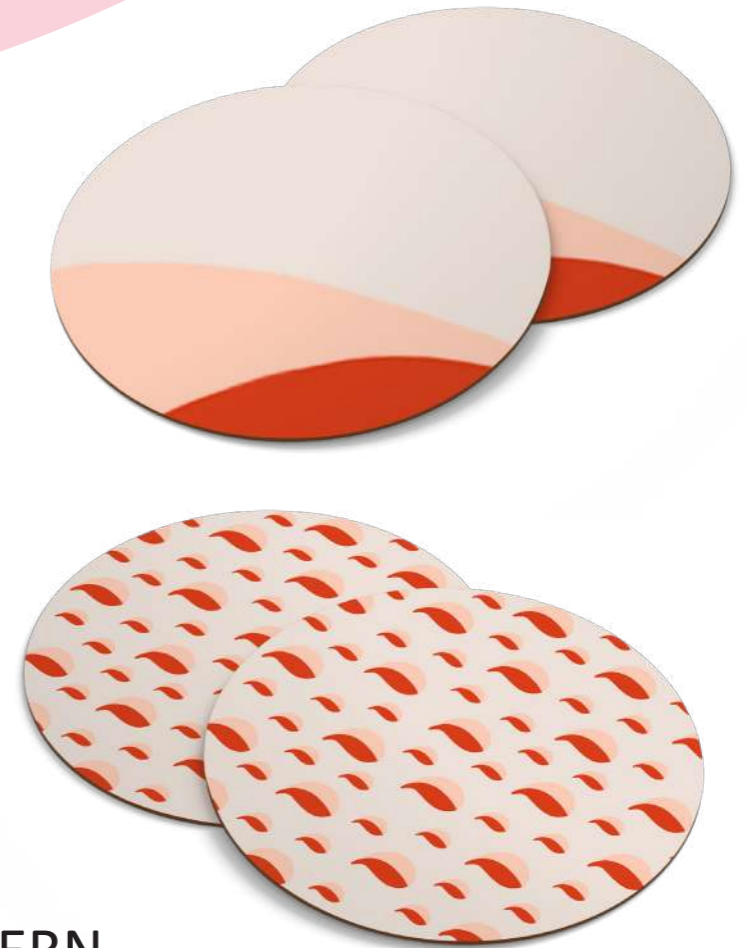

1 PATTERN

- SMALL
- LARGE

PROMOTIONAL ITEMS

RHODO CANDLE



1 COLOR

- SOLMON PINK
- REDDISH ORANGE

PROMOTIONAL ITEMS

RHODO AIR FRESHENER



1 COLOR

- SOLMON PINK
- REDDISH ORANGE



PROMOTIONAL ITEMS

RHODO CLEANING SPRAY



1 SIZE

- SMALL (100ml)
- LARGE (750ml)



PROMOTIONAL ITEMS

RHODO CLEANING FABRIC

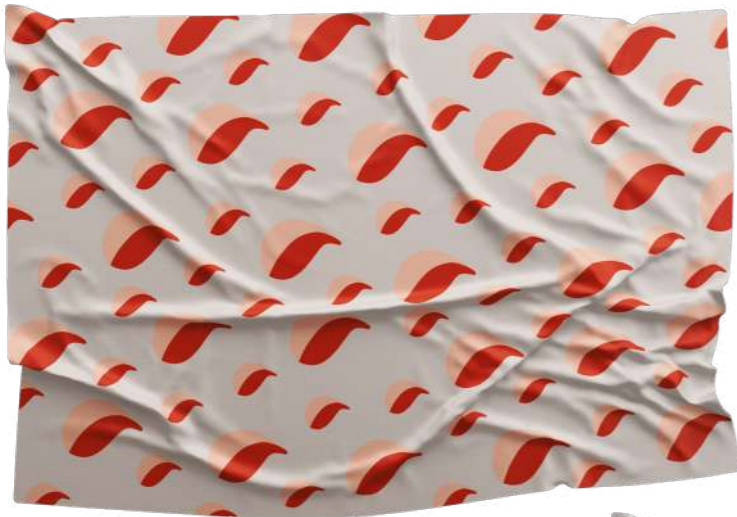

1 FABRIC

- PATTERN
- LOGO
- TEXT



PACKAGING

***For Promotional Products

(100x160x90cm) One Piece Package

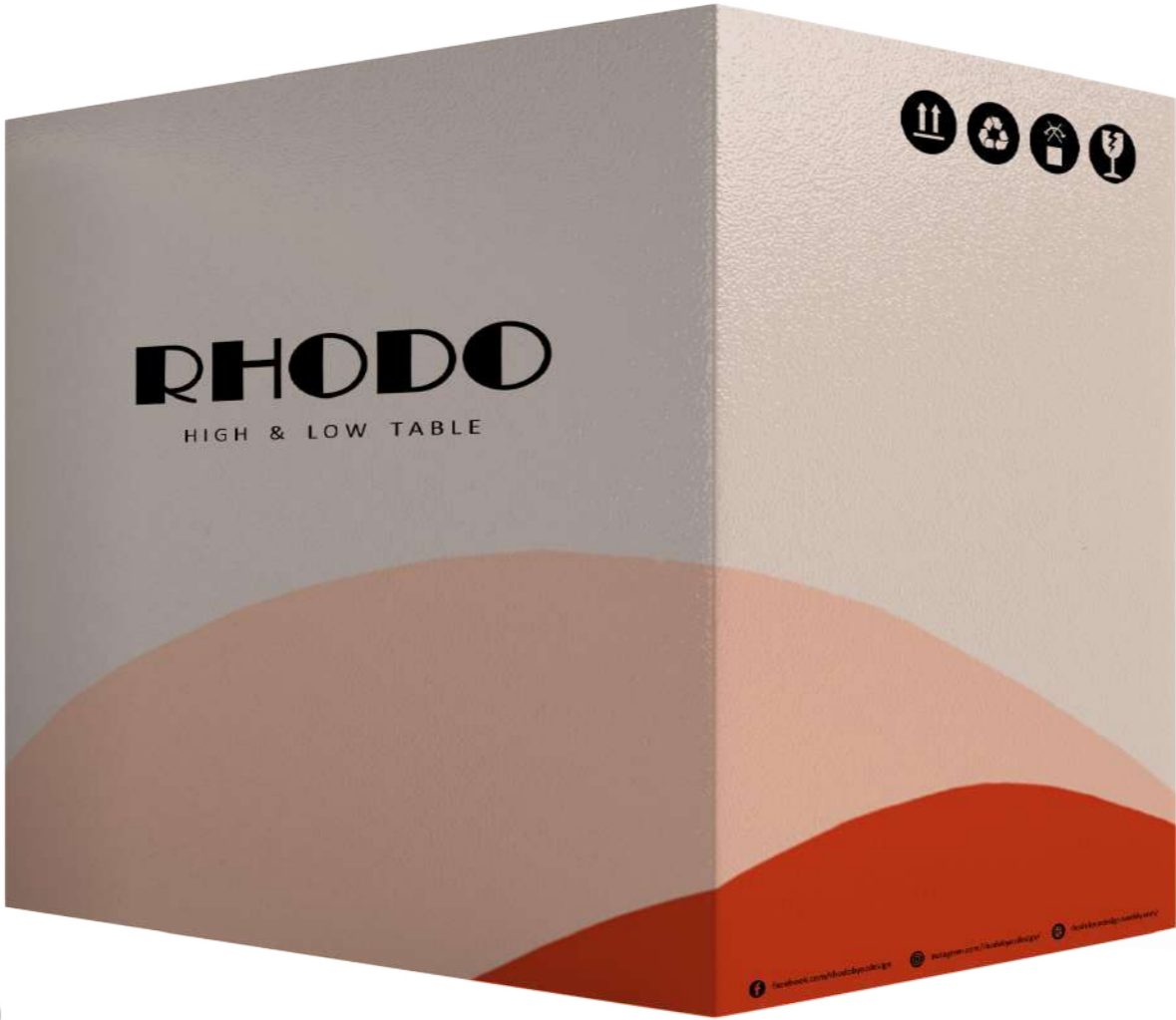

RHODO is delivered to the address as installed and packaged.

PACKAGING
***For RHODO High&Low Tables

USER MANUAL



ÖZGE İLHAN

ÖZ DESIGN

*Was born on the 1st of March, 1996 in Diyarbakır.

* Graduated from Tekirdağ Municipality Anatolian Teachers Highschool in 2014.

*Started her undergraduate design education in *İzmir University of Economics* in the department of *Interior Architecture and Environmental Design*.

*Also started doing double major with the department of *Industrial Design*.

*After graduation, applied masters degree in the field of *Design Studies* in 2020.

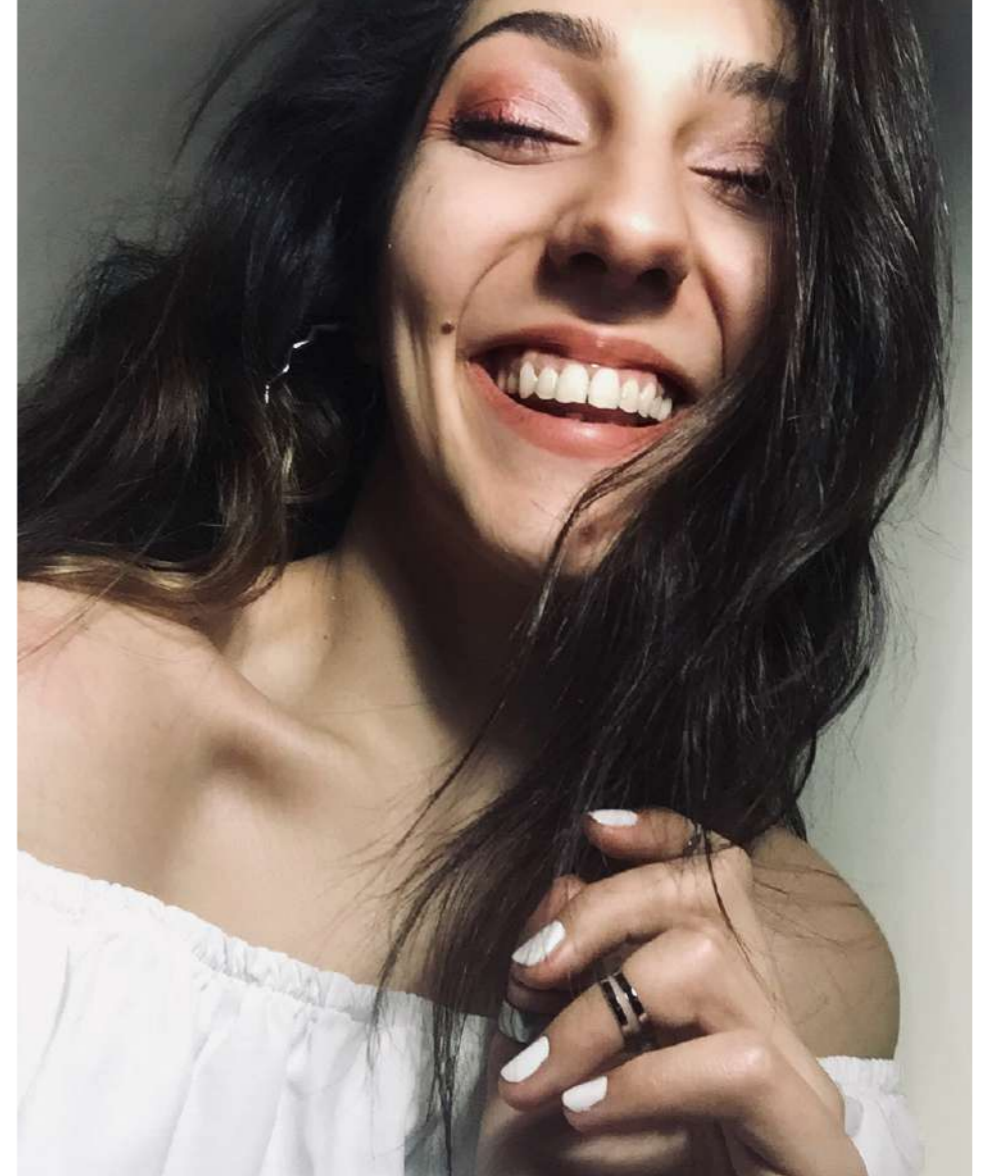

DESIGNER

33



THANKS
TO

Asst. Prof. Can ÖZCAN



Dr. Derya IRKDAŞ DOĞU